

New

**SUMAKE**  
MAKE JOBS BETTER THAN EVER

# 95/16 Pneumatic Plier

*Flexibility . Secure Closure . Time Saving*

## Application

95/16BJ(LJ) fastening cartons and containers, fiberboard, corrugated trays and wrappings, pallet boxes.  
95/16SJ fastening Upholstered furniture, Bedding.

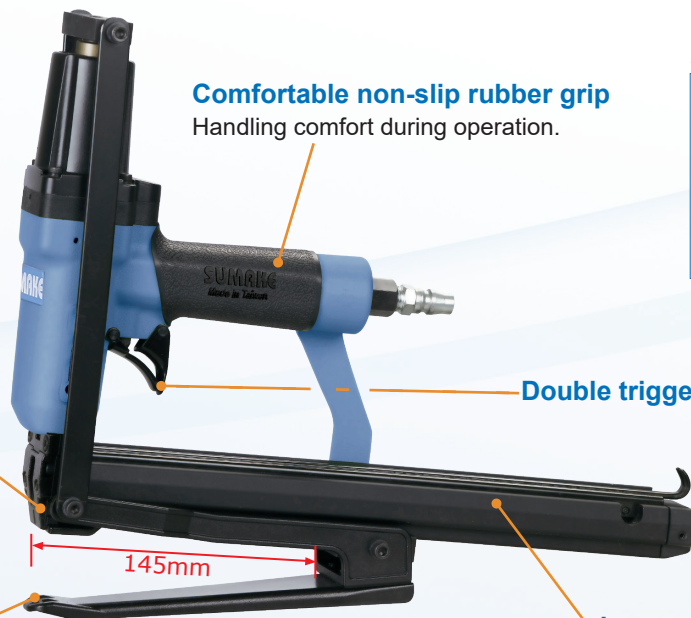
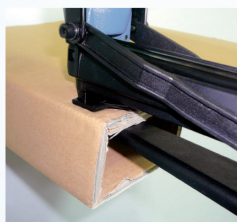

**Comfortable non-slip rubber grip**  
Handling comfort during operation.

### Fastener specification

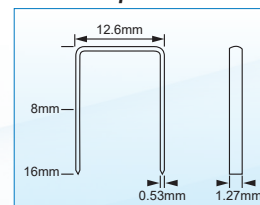

**Double trigger safety design**

Secure Closure Without Surface Damage.

**Flexibility of large throat**

Throat depth 145mm, this plier can reach deep inside the carton.

**95/16BJ**

**Large capacity magazine**

Loading capacity 168 pcs.

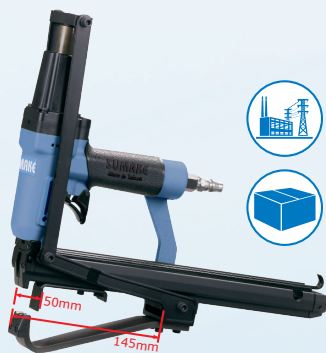

**95/16LJ**



**95/16SJ**

## Specification:

Model No.	Compatible Model	Fastener			Tool Specifications							
		Crown (mm)	Shank Thickness (mm)	Shank Width (mm)	Length		Pressure		Dimensions (HxWxL) (mm)	Net Weight		Load Capacity
					mm	inch	bar	psi		kgs	lbs	
95/16BJ	BeA 95/16-418	12.6	0.53	1.27	8-16	5/16 - 5/8	4.0-7.0	60-100	306X63X362	2.2	4.85	168 pcs
95/16LJ	BeA 95 staple	12.6	0.53	1.27	8-16	5/16 - 5/8	4.0-7.0	60-100	325X63X362	2.2	4.85	168 pcs
95/16SJ	BeA 95/16-414	12.6	0.53	1.27	8-16	5/16 - 5/8	4.0-7.0	60-100	302X63X362	2.1	4.63	168 pcs

## SUMAKE Industrial Co., Ltd.

4F, No.351, Yangguang St., Neihu District, Taipei, Taiwan, Zip:114-91  
Tel: 886-2-2659-3500 Fax: 886-2-2659-3700  
http://www.sumake.com e-mail: sales@sumake.com.tw



Certificate TW04/02301



XPST-N23-0728