

INDUSTRIAL AIR SCREWDRIVER

Intelligent Design / High Accuracy Assurance

ISO 9001



Certificate TW04/02301



SUMAKE[®]

MAKE JOBS BETTER THAN EVER

CE

SUMAKE COMPANY PROFILE

Sumake is a manufacturer and exporter specializing in professional high quality pneumatic tools, compressors and accessories suited to a wide range of applications including industrial and automotive.

We are an innovative company.

As a result of constant research and investment we keep at the forefront of current technology and design, thus providing energy efficient, durable and reliable products to industrial markets around the world.

We offer a wide, comprehensive range of CE certified tools and accessories including: Impact Wrenches, Ratchet Wrenches, Sanders, Screwdrivers, Spray Guns, Riveters, Nail Guns and Bradders, just to name a few.

Certified to ISO 9001 we run efficient well organized computerised Q.C. ensure we meet quality, packaging and delivery benchmarks.

We guarantee our customers complete spare parts back up for everything we provide.









Superior service to our customers is not a goal, it's a reality.

Sumake, partners in business.



SUMAKE has attended many international exhibitions and is known for a variety of high-end innovations with vivid posters. Our outstanding showcase is not only eye-catching but also provides hands-on experience for visitors.

INDEX

AUTO SHUT OFF		INTELLIGENT DESIGN AIR SCREWDRIVER	P1
		AN EVOLUTIONARY UPGRADE OF AIR SCREWDRIVER	P2 ~ 5
AUTO SHUT OFF		AIR SCREWDRIVER (APP,ABP series)	P6 ~ 8
DIRECT DRIVEN TYPE		AIR SCREWDRIVER & DRILL (ADPN,ADDN series)	P9
CUSHION TYPE		AIR SCREWDRIVER & DRILL (ACPN,ACDN,CS,CD series)	P10 ~ 12
AUTO SHUT OFF		AIR NUTRUNNER	P13 ~ 15
OPEN-END		AIR OPEN-END WRENCH	P16 ~ 17
HIGH TORQUE		OIL FREE AIR ANGLE WRENCH	P18
OIL FREE		OIL FREE AIR REVERSIBLE DIE GRINDER	P19
RECOMMENDATION		TORQUE ARM	P20
		TOOL HOLSTER / SPRING BALANCER	P21

Intelligent Design Air Screwdriver *Auto Shut-off*

1 New Tornado Motor

Based on SUMAKE original MCL cross switch motor, upgraded patent tornado motor provides 60% more torque power and 30~40% less counterforce than original MCL version. Noise level is about 67(±2)dBA, which has decreased by 5-6dBA than MCL motor, which not only prevents operators from hearing damage but also meets industrial regulations.

2 Patent Reverse Floating Button

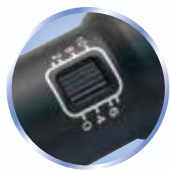

FP035



FPB030: 3 Nm

3 Patent Mechanical Torque Value Display U Window

Repeatability Accuracy
±2%

4 Speediness

Operator can change the bit rapidly by pulling the bit sleeve.

5 Torque Protection Cover

6 Comfort

Uniquely shaped resin grip with ergonomic "Top Wave" design, best balance and easy to grip. The grip is made of thermoplastic elastomer, the best material so far, with good touch and anti-glossy feature.

7 Suspension Ring

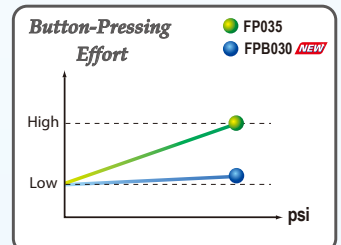
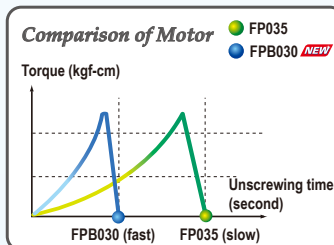
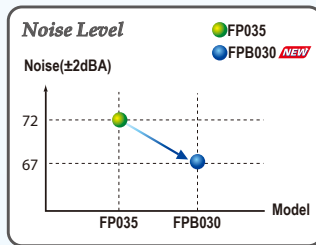
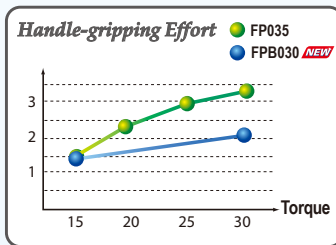

Model No.	Free Speed (r.p.m)	Torque Range		Weight (g)	O.A.L. (mm)	Dia. (mm)	Noise (±3dB(A))	Min. Air Hose bore(mm)	Air Consumption (m³/min)	Fastening Capacity	
		N.m	kgf/cm							Machine Screw Dia.	Tapping Screw Dia.
FPB030	1000	0.5-3	5-30	580	240	34	67	5.0	0.28	M2.2-M5.0	M1.7-M4.1
FPB085	1000	1.5-8.5	15-85	980	298	42	72	8.0	0.55	M4.1-M7.0	M3.1-M6.0

The Appearance

SUMAKE engaging the design and manufacture of air screwdriver. From the user's point of view to plan the product map. From the owner's point of view to calculate the efficiency of tool. Furthermore, base on accuracy, environment, technology and quality, **SUMAKE** owns several patents and awards. An excellent air screwdriver tool can increase not only efficiency but the quality. A REAL industrial Air screwdriver with 2003 newest total design by the engineers of body, mechanic and ergonomics.

SUMAKE® air screwdriver has following 18 features

- 1 Accuracy** : **SUMAKE** provide patent clutch with 3% deviation of torque, assure the best quality.
- 2 Meet ISO5393 Standard** : With patented cross-path MSC clutch and special mechanical structure, meet ISO5393 B class CPK value Torque deviation request (CPK value > 1.33).
- 3 Economic** : Wide-ranging torque with many patent and longer life cycle of motor.
- 4 Delicacy** : Combination of art, ergonomics and mechanical design.
- 5 Technology** : Special mechanical structure and patent motor give you low noise, low vibration and high accuracy.
- 6 Honorary** : Award "Excellent Tool" at Japan 2002 Osaka exhibition.



7 Easy Operation

Special design of level for easy operation.

8 Comfort

Uniquely shaped soft resin for ergonomic grip "Top Wave" ergonomic design, best balance and easy to grip. The grip made thermoplastic elastomer, the best material so far, with good touch and anti-glossy feature.

9 Speediness

Operator can change the bit rapidly by pulling the bit sleeve.

10 Torque Rings

SUMAKE Color Rings give you an easily visible torque marking system at a glance. Choice the color for each torque level used on your assemble line.

11 360° swivel Air Inlet

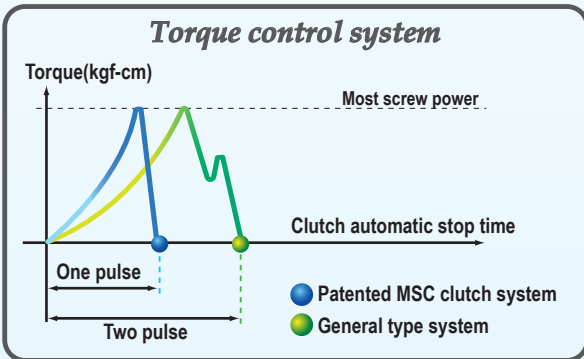

SUMAKE Patented MSC cross-path patent clutch system (Automatic start-off type)

The one pulse has the merits of low vibration (less than 2.5m/s²) and low torque deviation (±3%).

Others General type

2-3 times vibration (over 2.5m/s²) when pulse with higher torque deviation.

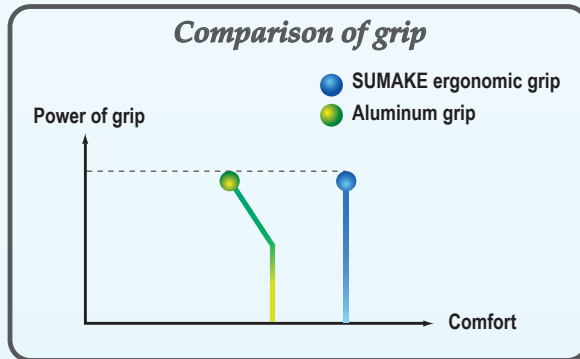

SUMAKE Patented **SUMAKE**® ergonomic grip

More comfortable for operator to raise efficiency.

Others General type

To feel uncomfortable when grip long time.

Disassembly Chart

A New experience of less noise and easy maintenance.



14 Torque fix system

To avoid the adjustment by operator and easy to mark the torque through the window This up to date design let you either adjust the torque rapidly or without using the torque lock nut.

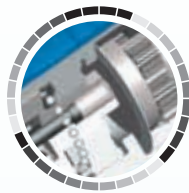

13 One pulse with $\pm 3\%$ low deviation (Pat. No. 149380), **MSC** cross-path patent clutch system.

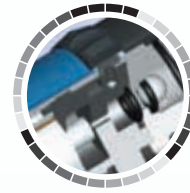

12 (One-handed operation) Turn and change the rotary direction.

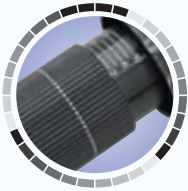

15 External Torque Adjustment Ring Turn right to increase and left to decrease.



18 High technologic patent **MCL** motor with more 30% power than general type. (Pat. No. 151110)

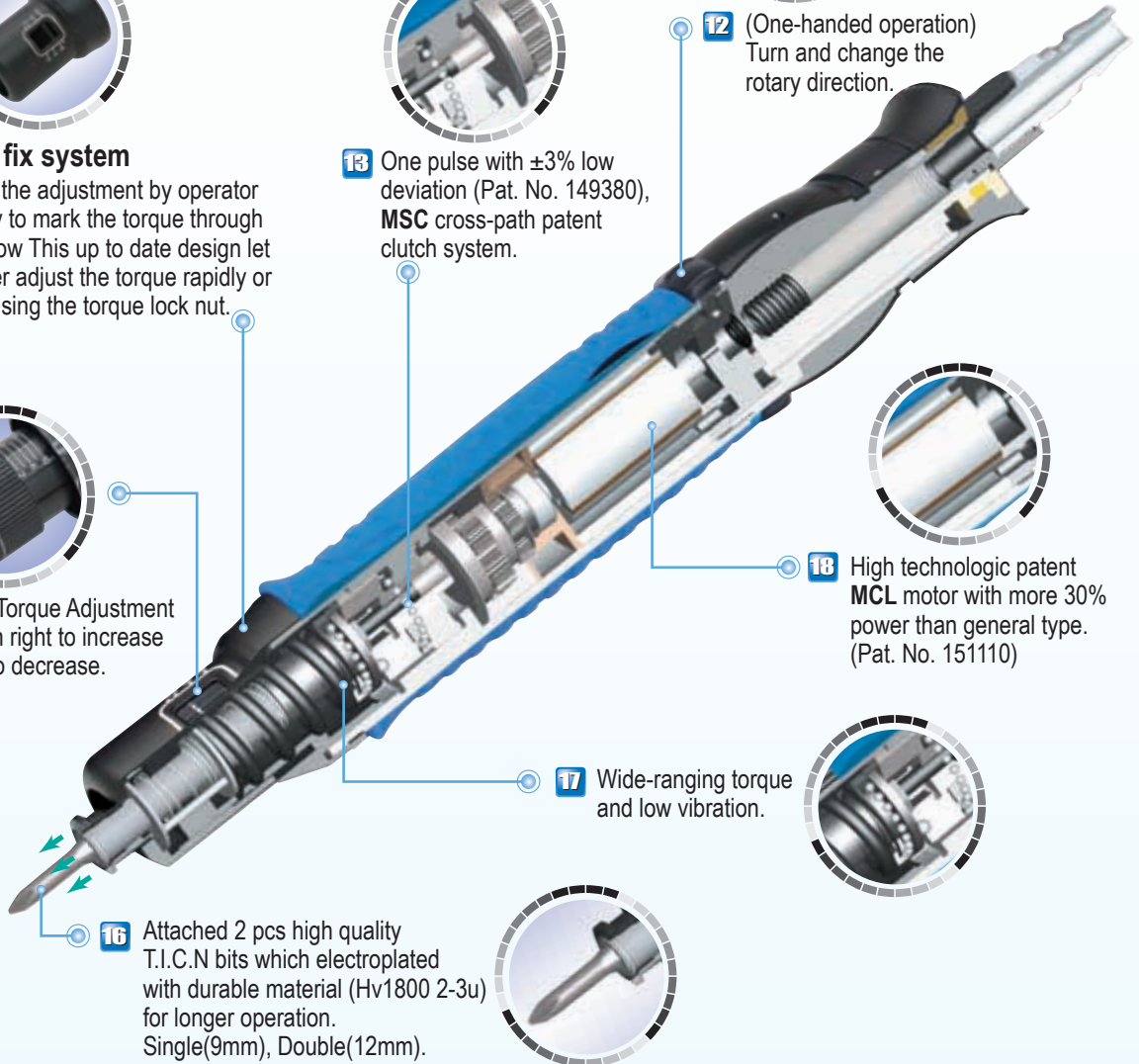

16 Attached 2 pcs high quality T.I.C.N bits which electroplated with durable material (Hv1800 2-3u) for longer operation. Single(9mm), Double(12mm).



17 Wide-ranging torque and low vibration.

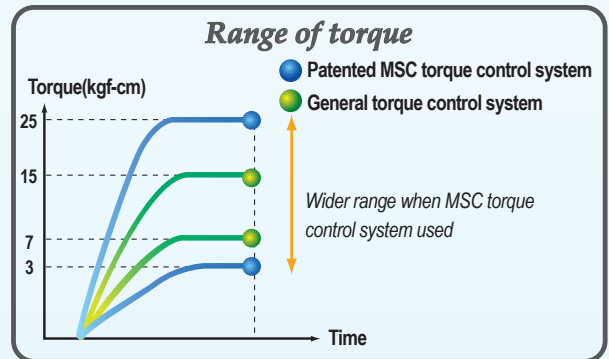
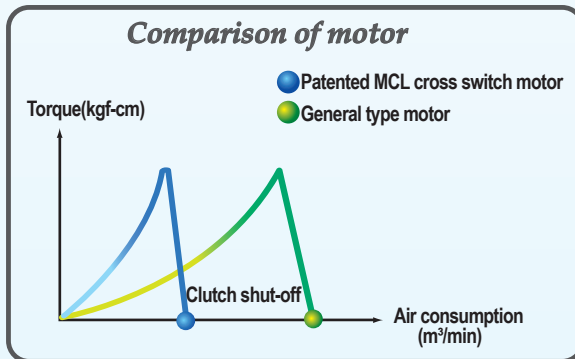

SUMAKE Patented MCL cross switch control system (Automatic start shut-off type)

MCL cross switch motor provide 40% more power and torque than general type.

Others General type

Low power, higher air consumption with lower efficiency.

SUMAKE Patented MSC clutch system.

More wider range of torque when patented motor used. *When **SUMAKE** model FP025 used.

Others General type

Limited torque range.

SUMAKE[®] INDUSTRIAL FULL AUTO SHUT-OFF AIR SCREWDRIVER

Meet ISO5393 Standard B class CPK value. Torque deviation request (CPK value > 1.33)

Economic : Wide-ranging torque with many patent and longer life cycle of motor

Accuracy: 3% deviation of torque, assure the best quality



An Evolutionary Upgrade of Air Screwdriver *Auto Shut-off*



Push Start



Lever Start



*Model FAW020 ~ 050
With 1/4" Square
(3/8" Square for Opt.)

*Model FAW060 ~ 280
With 3/8" Square



Lever Start, Angle Type

Recommend Air Pressure: 6.0 Kg/cm²

Model No.	Free Speed (r.p.m.)	Torque Range ±3%		Weight (g)	O.A.L (mm)	Dia. (mm)	Noise (±3dB(A))	Min. Air Hose bore (mm)	Air Consumption (m ³ /min)	Fastening Capacity		
		Nm	Kgf-cm							Machine Screw Dia.	Tapping Screw Dia.	
Push Start												
FP010	1000	0.1-1	1-10	600	250	35	68	5.0	0.20	M1.7-M3.7	M1.3-M2.9	
FP020	2200	0.3-2	3-20	600	250	35	72	5.0	0.28	M2.2-M4.5	M1.7-M3.5	
FP025	1800	0.3-2.5	3-25	600	250	35	72	5.0	0.28	M2.2-M4.7	M1.7-M3.8	
FP035	1000	0.5-3.5	5-35	600	250	35	72	5.0	0.28	M2.8-M5.0	M2.2-M4.0	
FP045	800	0.8-4.5	8-45	600	250	35	72	5.0	0.30	M3.3-M5.8	M2.7-M4.7	
FP050	550	1-5	10-50	600	250	35	72	5.0	0.30	M3.5-M6.0	M2.8-M4.9	
FP060	2200	2-6	20-60	880	285	43	76	8.0	0.55	M3.5-M6.4	M2.8-M5.4	
FP075	1000	1.2-7.5	12-75	880	285	43	76	8.0	0.55	M4.1-M6.9	M3.1-M5.9	
FP110	550	3-11	30-110	880	285	43	76	8.0	0.55	M5.0-M7.8	M4.0-M6.3	
FP180	300	3-18	30-180	900	285	43	76	8.0	0.55	M5.0-M9.3	M4.0-M7.2	
FP280	250	5-28	50-280	900	285	43	76	8.0	0.55	M6.0-M11.0	M4.9-M8.7	
Lever Start												
FL010	1000	0.1-1	1-10	630	250	35	68	5.0	0.20	M1.7-M3.7	M1.3-M2.9	
FL020	2200	0.3-2	3-20	630	250	35	72	5.0	0.28	M2.2-M4.5	M1.7-M3.5	
FL025	1800	0.3-2.5	3-25	630	250	35	72	5.0	0.28	M2.2-M4.7	M1.7-M3.8	
FL035	1000	0.5-3.5	5-35	630	250	35	72	5.0	0.28	M2.8-M5.0	M2.2-M4.0	
FL045	800	0.8-4.5	8-45	630	250	35	72	5.0	0.30	M3.3-M5.8	M2.7-M4.7	
FL050	550	1-5	10-50	630	250	35	72	5.0	0.30	M3.5-M6.0	M2.8-M4.9	
FL060	2200	2-6	20-60	900	285	43	76	8.0	0.55	M3.5-M6.4	M2.8-M5.4	
FL075	1000	1.2-7.5	12-75	900	285	43	76	8.0	0.55	M4.1-M6.9	M3.1-M5.9	
FL110	550	3-11	30-110	900	285	43	76	8.0	0.55	M5.0-M7.8	M4.0-M6.3	
FL180	300	3-18	30-180	920	285	43	76	8.0	0.55	M5.0-M9.3	M4.0-M7.2	
FL280	250	5-28	50-280	920	285	43	76	8.0	0.55	M6.0-M11.0	M4.9-M8.7	
Lever Start, Angle Type												
FA020	2200	0.3-2	3-20	770	310	35	70	5.0	0.28	M2.2-M4.5	M1.7-M3.5	
FA035	1000	0.5-3.5	5-35	770	310	35	74	5.0	0.28	M2.8-M5.0	M2.2-M4.0	
FA045	800	0.8-4.5	8-45	770	310	35	74	5.0	0.30	M3.3-M5.8	M2.7-M4.7	
FA050	550	1-5	10-50	770	310	35	74	5.0	0.30	M3.5-M6.0	M2.8-M4.9	
FA060	2200	2-6	20-60	1350	345	43	74	8.0	0.55	M3.5-M6.4	M2.8-M5.4	
FA075	1000	1.2-7.5	12-75	1350	345	43	78	8.0	0.55	M4.1-M6.9	M3.1-M5.9	
FA110	550	3-11	30-110	1350	345	43	78	8.0	0.55	M5.0-M7.8	M4.0-M6.3	
FA180	300	3-18	30-180	1450	345	43	78	8.0	0.55	M5.0-M9.3	M4.0-M7.2	
FA280	250	5-28	50-280	1450	345	43	78	8.0	0.55	M6.0-M11.0	M4.9-M8.7	

*The standard bit is 1/4", if φ 5mm, put "A" in the end Ex. FP010A

SUMAKE Air Screwdriver has following 15 features

SUMAKE A-series have multi-start function: Push start / Push - Trigger start / Trigger start function.

- 1 Technology** : Special mechanical structure and patent motor give you low noise, low vibration and high accuracy.
- 2 Accuracy** : **SUMAKE** provide patent clutch with 3% deviation of torque, assure the best quality.
- 3 Light Weight**: All new patent mechanical design and grip material 25~44% lighter than other brand.
- 4 Delicacy** : Combination of art, ergonomics and mechanical design.

5 User Friendly operation

Easy to switch the direction(F/R) by single hand.

9 Flexible inlet design feature

The air inlet direction can be option for assembly line to get flexible space.

6 Speediness

Operator can change the bit rapidly by pulling the slide sleeve.

7 Trigger auto lock feature

World first proprietary auto lock feature(APP type only) with the choice of PUSH or PUSH To Start (to avoid any damage on surface and more safety for operator) can increase the quality of screwing.

8 Comfort

Uniquely shaped ergonomic design with anti-slip to provide best balance and comfort in operation.

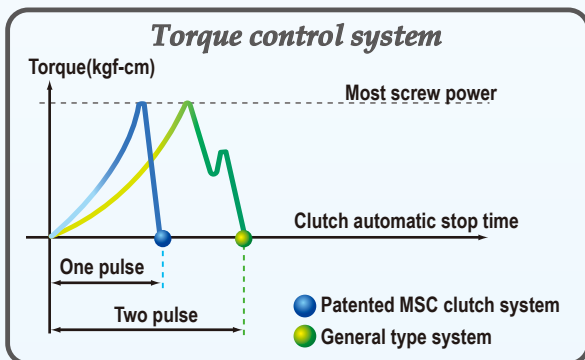

- SUMAKE** Patented MSC cross-path patent clutch system (Automatic start-off type)
The one pulse has the merits of low vibration (less than 2.5m/s²) and low torque deviation (±3%).
- Others** General type
2-3 times vibration (over 2.5m/s²) when pulse with higher torque deviation.

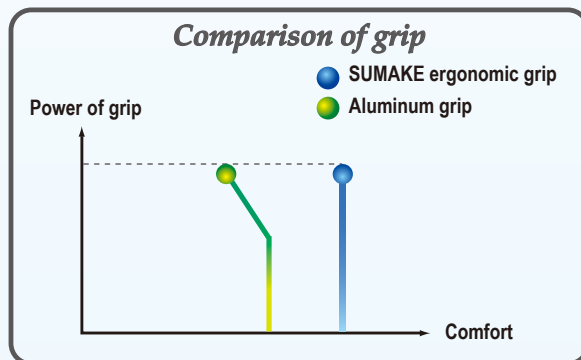

- SUMAKE** Patented **SUMAKE** ergonomic grip
More comfortable for operator to raise efficiency.
- Others** General type
To feel uncomfortable when grip long time.

Disassembly Chart



12 Attached 2 pcs high quality T.I.C.N. bits which electroplated with durable material (Hv1800 2-3u) for longer operation. Single(9mm), Double(12mm)

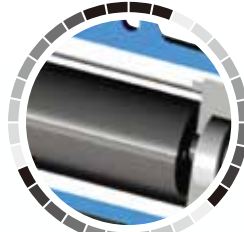

11 High technologic patent MCL motor with more 30% power than general type. (pat. No.151110)



10 (Single-handed operation) Turn and change the rotary direction.

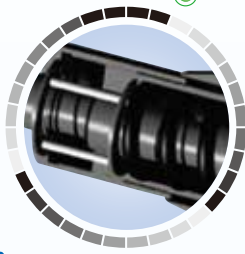

13 The torque nut used for: Color torque system torque fix system adjust the torque rapidly. Turn right to increase and left to decrease.



14 Wide-ranging torque and low vibration.

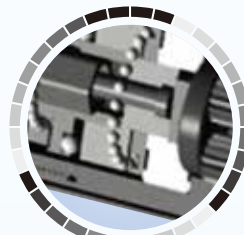

15 One pulse with $\pm 3\%$ low deviation (Pat. No.149380), MSC cross-path patent clutch system.

Comparison of motor

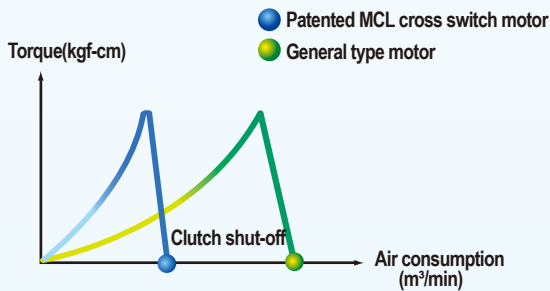

Range of torque

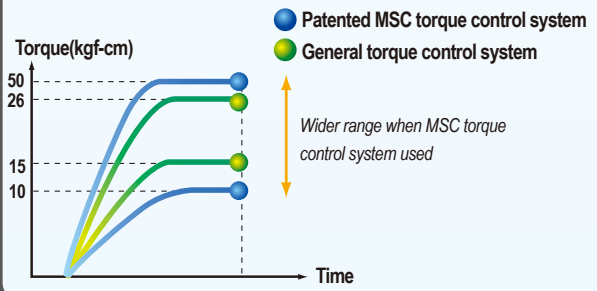

SUMAKE Patented MCL cross switch control system (Automatic start shut-off type)
 MCL cross switch motor provide 30% more power and torque than general type.

Others General type
 Low power, higher air consumption with lower efficiency.

SUMAKE Patented MSC clutch system.
 More wider range of torque when patented motor used. *When **SUMAKE** model APP47 used.

Others General type
 Limited torque range.

Push start or Push & Trigger start shut off



*Air Inlet could be 3 way option



**APP38
APP41
APP47**

<Small Body> -Light Weight-



**APP48 APP60
APP50 APP65
APP55 APP68**

<Standard Body>

Option:

* APPT is for push-trigger to start (w/o lock pin) Ex. APPT38.

Model No.	Drive	Free Speed (r.p.m.)	Torque Range±3%		Weight (g)	Dimension (Ø x L x H) (mm)	Air Pressure (Kg/cm ²)	Noise Level (±3dB(A))	Min. Air Hose Bore (mm)	Air Consumption (m ³ /min)	Fastening Capacity	
			N.m	Kgf-cm							Machine Screw Dia. T	Tapping Screw Dia. 2T
APP38	○F1/4"	1800	0.3-2.5	3-25	690	33 x 195 x 150	6.0	72	5.0	0.28	M2.2-M4.7	M1.7-M3.8
APP41	○F1/4"	1000	0.5-3.5	5-35	690	33 x 195 x 150	6.0	72	5.0	0.28	M2.8-M5.2	M2.2-M4.2
APP47	○F1/4"	550	1-5	10-50	690	33 x 195 x 150	6.0	72	5.0	0.28	M3.6-M6.0	M2.8-M4.7
APP48	○F1/4"	2200	1-6	10-60	1030	39 x 230 x 160	6.0	76	8.0	0.55	M3.6-M6.2	M2.8-M5.1
APP50	○F1/4"	1400	1-6	10-60	1030	39 x 230 x 160	6.0	76	8.0	0.55	M3.6-M6.2	M2.8-M5.1
APP55	○F1/4"	1000	1.2-7.5	12-75	1030	39 x 230 x 160	6.0	76	8.0	0.55	M3.8-M6.6	M3.0-M5.6
APP60	○F1/4"	550	3-11	30-110	1030	39 x 230 x 160	6.0	76	8.0	0.55	M5.0-M7.3	M4.0-M6.2
APP65	○F1/4"	300	3-18	30-180	1150	39 x 235 x 160	6.0	76	8.0	0.55	M5.0-M9.3	M4.0-M7.2
APP68	○F1/4"	250	5-28	50-280	1150	39 x 235 x 160	6.0	76	8.0	0.55	M6.0-M11.0	M4.9-M8.7

* If Ø5mm, put "A" in the end Ex. APP38A

* Standard air inlet direction up bottom only. If need three-direction air inlet up bottom rear, put "T" in the end Ex. APP38T.

Trigger start-shut off



*Air Inlet could be 3 way option



**ABP38
ABP41
ABP47**

<Small Body> -Light Weight-



**ABP48 ABP60
ABP50 ABP65
ABP55 ABP68**

<Standard Body>

Option:

* ASP is push start Ex. ASP38. Standard air inlet is from rear only. (w/o lock pin) Other air inlet direction please specify.

Model No.	Drive	Free Speed (r.p.m.)	Torque Range±3%		Weight (g)	Dimension (Ø x L x H) (mm)	Air Pressure (Kg/cm ²)	Noise Level (±3dB(A))	Min. air hose bore (mm)	Air Consumption (m ³ /min)	Fastening Capacity	
			N.m	Kgf-cm							Machine Screw Dia. T	Tapping Screw Dia. 2T
ABP38	○F1/4"	1800	0.3-2.5	3-25	690	33 x 195 x 150	6.0	72	5.0	0.28	M2.2-M4.7	M1.7-M3.8
ABP41	○F1/4"	1000	0.5-3.5	5-35	690	33 x 195 x 150	6.0	72	5.0	0.28	M2.8-M5.2	M2.2-M4.2
ABP47	○F1/4"	550	1-5	10-50	690	33 x 195 x 150	6.0	72	5.0	0.28	M3.6-M6.0	M2.8-M4.7
ABP48	○F1/4"	2200	1-6	10-60	1030	39 x 230 x 160	6.0	76	8.0	0.55	M3.6-M6.2	M2.8-M5.1
ABP50	○F1/4"	1400	1-6	10-60	1030	39 x 230 x 160	6.0	76	8.0	0.55	M3.6-M6.2	M2.8-M5.1
ABP55	○F1/4"	1000	1.2-7.5	12-75	1030	39 x 230 x 160	6.0	76	8.0	0.55	M3.8-M6.6	M3.0-M5.6
ABP60	○F1/4"	550	3-11	30-110	1030	39 x 230 x 160	6.0	76	8.0	0.55	M5.0-M7.3	M4.0-M6.2
ABP65	○F1/4"	300	3-18	30-180	1150	39 x 235 x 160	6.0	76	8.0	0.55	M5.0-M9.3	M4.0-M7.2
ABP68	○F1/4"	250	5-28	50-280	1150	39 x 235 x 160	6.0	76	8.0	0.55	M6.0-M11.0	M4.9-M8.7

* If Ø5mm, put "A" in the end Ex. ABP38A

* 3/8" square available from ABP48-68, and code change to AWP48-68

* Standard air inlet direction up bottom only. If need three-direction air inlet up bottom rear, put "T" in the end Ex. ABP38T.

Trigger Start Air Screwdriver **Direct Driven Type** (Without Clutch)



Model No.	Drive	Bolt Capacity (mm)	Max. Torque Hard Joint		No Load Speed (r.p.m.)	Dimension (Ø x L x H) (mm)	Avg. Air Consumption		Weight (g)	Noise Level (±3dB(A))	Min. Air Hose Bore (I.D.)
			N-m	Ft-lb			cfm	m³/min			
ADPN39	⬡ F1/4"	3 ~ 5	5.0	3.7	1600	36 x 140 x 142	10	0.28	550	72	5mm
ADPN45	⬡ F1/4"	3 ~ 6	7.0	5.0	750	36 x 146 x 142	10	0.28	550	72	5mm
ADPN48	⬡ F1/4"	3 ~ 6	7.0	5.0	1700	45 x 159 x 154	19	0.55	780	76	8mm
ADPN58	⬡ F1/4"	3 ~ 7	13.0	9.6	750	45 x 159 x 154	19	0.55	780	76	8mm

*With "N" : Trigger start only.

*W/O "N" (ADP39) : Two way operations. (One is trigger locked up with pin and works by push-down; the other works by trigger-on & push-down together.)

Trigger Start Air Drill **Direct Driven Type** (Without Clutch)



Model No.	Drilling Cap		Bolt Capacity (mm)	Max. Torque Hard Joint		No Load Speed (r.p.m.)	Dimension (Ø x L x H) (mm)	Avg. Air Consumption		Weight (g)	Noise Level (±3dB(A))	Min. Air Hose Bore (I.D.)
	mm	inch		N-m	Ft-lb			cfm	m³/min			
ADDN26	6	1/4	3 ~ 5	3.5	2.6	2900	36 x 140 x 142	10	0.28	630	72	5mm
ADDN39	10	3/8	3 ~ 5	5.0	3.7	1600	36 x 140 x 142	10	0.28	630	72	5mm
ADDN48	10	3/8	3 ~ 6	7.0	5.0	1700	45 x 159 x 150	19	0.55	970	76	8mm
ADDN58	10	3/8	3 ~ 6	13.0	9.6	750	45 x 159 x 150	19	0.55	970	76	8mm
ADDN458	13	1/2	3 ~ 6	13.0	9.6	750	45 x 159 x 150	19	0.55	1060	76	8mm

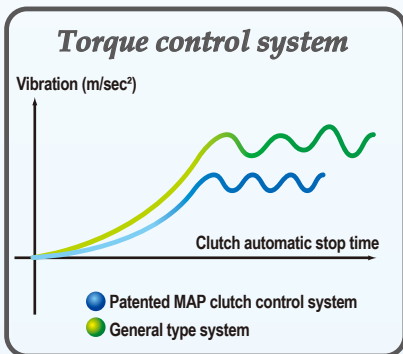

SUMAKE Patented MAP clutch control system
Lower vibration for more accurate torque control.

Other General type
Higher vibration.

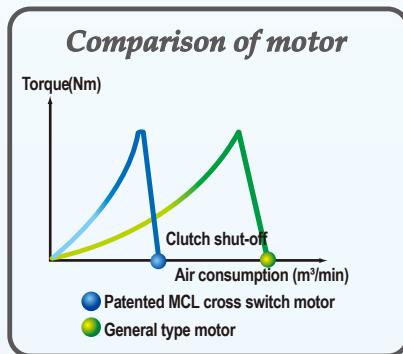

SUMAKE Patented MCL cross switch control system
MCL cross switch motor provide 30% more power and torque than general type.

Other General type
lower power, higher air consumption with lower efficiency.

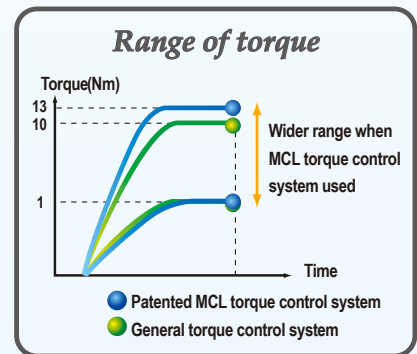

SUMAKE Patented MCL torque control system
More wider range of torque when patented motor used.
*When **SUMAKE** model ACPN58 used.

Other General type
Limited torque range.

Trigger start Air Screwdriver Cushion Type

(Torque External Adjustable)



Air Inlet could be 3 way option



ACPN39
ACPN45
<Small Body>
-Light Weight-



ACPN48
ACPN58
ACPN62
<Standard Body>

Model No.	Drive	Bolt Capacity (mm)	Torque Range Hard Joint (N-m)	No Load Speed (r.p.m.)	Dimension (Ø x L x H) (mm)	Avg. Air Consumption		Weight (g)	Noise Level (±3dB(A))	Min. Air Hose Bore (I.D.)
						cfm	m³/min			
ACPN39	◇ F1/4"	2.5 ~ 5.0	5.0	1600	36 x 140 x 142	10	0.28	600	72	5.0mm
ACPN45	◇ F1/4"	2.5 ~ 6.0	7.0	750	36 x 140 x 142	10	0.28	600	72	5.0mm
ACPN48	◇ F1/4"	3.0 ~ 6.0	7.0	1700	43 x 165 x 154	19	0.55	870	76	8.0mm
ACPN58	◇ F1/4"	3.0 ~ 7.0	13.0	750	43 x 165 x 154	19	0.55	870	76	8.0mm
ACPN62	◇ F1/4"	3.0 ~ 7.0	9.0	350	43 x 165 x 154	19	0.55	870	76	8.0mm

*With "N" : Trigger start only.

*W/O "N" (ACP39) : Two way operations. (One is trigger locked up with pin and works by push-down; the other works by trigger-on & push-down together.)

Trigger start 3 in 1 Air Drill & Screwdriver Cushion Type

(Torque External Adjustable)



Use Screw

Use Drilling

Use Tapping

Air Inlet could be 3 way option



ACDN39 10mm(3/8")
ACDN45 10mm(3/8")
<Small Body>
-Light Weight-



SH-0005

*Side handle for ACDN458 type



ACDN48 10mm(3/8")
ACDN58 10mm(3/8")
ACDN458 13mm(1/2")
<Standard Body>

Model No.	Drilling Cap		Bolt Capacity (mm)	Torque Range Hard Joint (N-m)	No Load Speed (r.p.m.)	Dimension (Ø x L x H) (mm)	Avg. Air Consumption		Weight (g)	Noise Level (±3dB(A))	Min. Air Hose Bore (I.D.)
	mm	inch					cfm	m³/min			
ACDN39	10	3/8	2.5~5.0	5.0	1600	36 x 165 x 142	10	0.28	750	72	5.0mm
ACDN45	10	3/8	2.5~5.0	7.0	750	36 x 165 x 142	10	0.28	750	72	5.0mm
ACDN48	10	3/8	3.0~6.0	7.0	1700	43 x 214 x 154	19	0.55	1100	76	8.0mm
ACDN58	10	3/8	3.0~7.0	13.0	750	43 x 214 x 154	19	0.55	1100	76	8.0mm
ACDN458	13	1/2	3.0~7.0	13.0	750	45 x 235 x 160	19	0.55	1100	76	8.0mm

Air Screwdriver Cushion Type (Torque External Adjustable)



CS39
CS45
<Small Body>
-Light Weight-



CS48
CS58
<Standard Body>

Model No.	Drive	Bolt Capacity (mm)	Torque Range Hard Joint (N.m)	No Load Speed (r.p.m.)	Dimension (Ø x L) (mm)	Avg. Air Consumption		Weight (g)	Noise Level (±3dB(A))	Min. Air Hose Bore (I.D.)
						cfm	m ³ /min			
CS39	⊕F1/4"	2.5 ~ 5.0	4.0	1600	35 x 140	10	0.28	600	72	5mm
CS45	⊕F1/4"	2.5 ~ 6.0	4.0	800	35 x 140	10	0.28	600	72	5mm
CS48	⊕F1/4"	3.0 ~ 6.0	6.0	1700	43 x 195	19	0.55	840	77	8mm
CS58	⊕F1/4"	3.0 ~ 7.0	9.0	750	43 x 195	19	0.55	840	77	8mm

3 in 1 Air Drill & Air Screwdriver Cushion Type (Torque External Adjustable)



Use Screw



Use Drilling



Use Tapping



CD39
CD48
CD58
<Standard Body>

Model No.	Drilling Cap		Torque Range Hard Joint (N.m)	No Load Speed (r.p.m.)	Dimension (Ø x L) (mm)	Avg. Air Consumption		Weight (g)	Noise Level (±3dB(A))	Min. Air Hose Bore (I.D.)
	mm	inch				cfm	m ³ /min			
CD39	10	3/8	5.0	1600	43 x 258	19	0.55	1022	76	8mm
CD48	10	3/8	7.0	1700	43 x 244	19	0.55	1000	77	8mm
CD58	10	3/8	13.0	750	43 x 244	19	0.55	1000	77	8mm

Air Nutrunner Air Start Shut-off

(Immediate and Automatic air shut-off) -Forward type-



*For Model **SM10 ~ SM45**

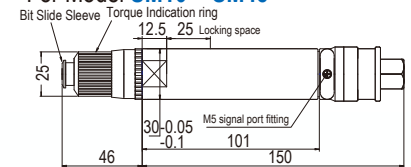

*For Model **SM48 ~ SM68**

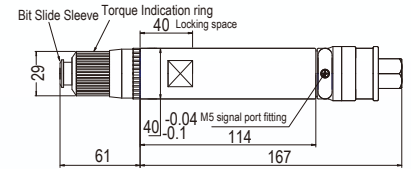

Model No.	Free Speed (r.p.m.)	O.A.L. (mm)	Dia. (mm)	Air Hose Bore		Air Consumption (m³/min)	Torque Range		Vibration Level (ms²)	Standard Deviation (%)	Fastening Capacity	
				6.0 Kg/cm³	5.0 Kg/cm³		N-m	Kgf-cm			Machine Screw T	Tapping Screw 2T
SM10	100	196	30	5.0	6.35	0.20	0.05-0.2	0.5-2	<1.0	±3	M1.0-M2.2	M1.1-M1.7
SM20	100	196	30	5.0	6.35	0.20	0.1-0.8	1-8	<1.0	±3	M1.7-M3.3	M1.3-M2.7
SM30	180	196	30	5.0	6.35	0.28	0.3-1.7	3-17	<1.2	±3	M2.2-M4.2	M1.6-M3.2
SM35	220	196	30	5.0	6.35	0.28	0.3-2	3-20	<1.2	±3	M2.4-M4.5	M2.0-M3.5
SM40	100	196	30	5.0	6.35	0.28	0.5-3	5-30	<1.2	±3	M2.8-M5.0	M2.3-M4.0
SM45	800	196	30	6.35	8.0	0.30	0.8-4	8-40	<1.6	±3	M3.0-M5.7	M2.7-M4.4
SM48	170	228	40	8.0	9.5	0.55	0.5-4.5	5-45	<2.5	±3	M2.8-M5.8	M2.3-M4.7
SM50	140	228	40	8.0	9.5	0.55	0.7-5	7-50	<2.5	±3	M2.9-M6.0	M2.6-M4.9
SM55	100	228	40	8.0	9.5	0.55	0.7-6.5	7-65	<2.5	±3	M2.9-M6.4	M2.6-M5.4
SM60	550	228	40	8.0	9.5	0.55	1.5-9.5	15-95	<2.5	±3	M4.1-M7.0	M3.3-M6.0
SM65	300	228	40	8.0	9.5	0.55	3-18	30-180	<2.5	±3	M5.0-M9.3	M4.0-M7.2
SM68	250	228	40	8.0	9.5	0.55	5-28	50-280	<2.5	±3	M6.0-M11.0	M4.9-M8.7

Air Nutrunner Push to Start Shut-off

(Immediate and Automatic air shut-off)



*For Model **SM(N)P10 ~ SM(N)P45**

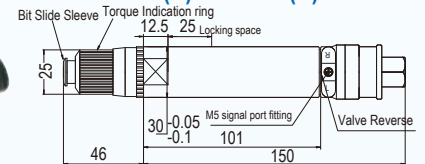

*For Model **SM(N)P48 ~ SM(N)P68**

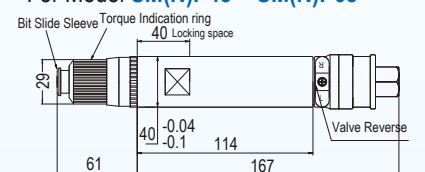

Model No.	Free Speed (r.p.m.)	O.A.L. (mm)	Dia. (mm)	Air Hose Bore		Air Consumption (m³/min)	Torque Range		Vibration Level (ms²)	Standard Deviation (%)	Fastening Capacity	
				6.0 Kg/cm³	5.0 Kg/cm³		N-m	Kgf-cm			Machine Screw T	Tapping Screw 2T
SM(N)P10	1000	196	30	5.0	6.35	0.20	0.05-0.2	0.5-2	<1.0	±3	M1.0-M2.2	M1.1-M1.7
SM(N)P20	1000	196	30	5.0	6.35	0.20	0.1-0.8	1-8	<1.0	±3	M1.7-M3.3	M1.3-M2.7
SM(N)P30	1800	196	30	5.0	6.35	0.28	0.3-1.7	3-17	<1.2	±3	M2.2-M4.2	M1.6-M3.2
SM(N)P35	2200	196	30	5.0	6.35	0.28	0.3-2	3-20	<1.2	±3	M2.4-M4.5	M2.0-M3.5
SM(N)P40	1000	196	30	5.0	6.35	0.28	0.5-3	5-30	<1.2	±3	M2.8-M5.0	M2.3-M4.0
SM(N)P45	800	196	30	6.35	8.0	0.30	0.8-4	8-40	<1.6	±3	M3.0-M5.7	M2.7-M4.4
SM(N)P48	1700	228	40	8.0	9.5	0.55	0.5-4.5	5-45	<2.5	±3	M2.8-M5.8	M2.3-M4.7
SM(N)P50	1400	228	40	8.0	9.5	0.55	0.7-5	7-50	<2.5	±3	M2.9-M6.0	M2.6-M4.9
SM(N)P55	1000	228	40	8.0	9.5	0.55	0.7-6.5	7-65	<2.5	±3	M2.9-M6.4	M2.6-M5.4
SM(N)P60	550	228	40	8.0	9.5	0.55	1.5-9.5	15-95	<2.5	±3	M4.1-M7.0	M3.3-M6.0
SM(N)P65	300	228	40	8.0	9.5	0.55	3-18	30-180	<2.5	±3	M5.0-M9.3	M4.0-M7.2
SM(N)P68	250	228	40	8.0	9.5	0.55	5-28	50-280	<2.5	±3	M6.0-M11.0	M4.9-M8.7

Air Nutrunner Air Start Shut-off

(Immediate and Automatic air shut-off) -environment protect-Forward type-

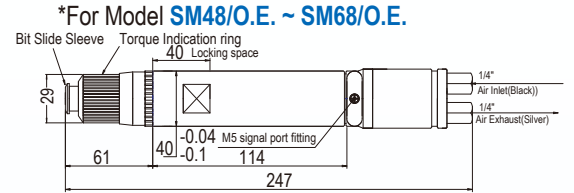
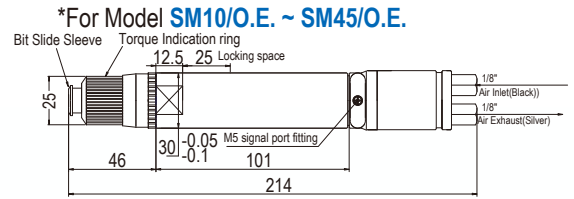

Model No.	Free Speed (r.p.m.)	O.A.L. (mm)	Dia. (mm)	Air hose bore		Air Consumption (m³/min)	Torque Range		Vibration Level (ms²)	Standard Deviation (%)	Fastening Capacity	
				6.0 Kg/cm³	5.0 Kg/cm³		N-m	Kgf-cm			Machine Screw	Tapping Screw
SM10/O.E.	1000	214	30	5.0	6.35	0.20	0.05-0.2	0.5-2	<1.0	±3	M1.0-M2.2	M1.1-M1.7
SM20/O.E.	1000	214	30	5.0	6.35	0.20	0.1-0.8	1-8	<1.0	±3	M1.7-M3.3	M1.3-M2.7
SM30/O.E.	1800	214	30	5.0	6.35	0.28	0.3-1.7	3-17	<1.2	±3	M2.2-M4.2	M1.6-M3.2
SM35/O.E.	2200	214	30	5.0	6.35	0.28	0.3-2	3-20	<1.2	±3	M2.4-M4.5	M2.0-M3.5
SM40/O.E.	1000	214	30	5.0	6.35	0.28	0.5-3	5-30	<1.2	±3	M2.8-M5.0	M2.3-M4.0
SM45/O.E.	800	214	30	6.35	8.0	0.30	0.8-4	8-40	<1.6	±3	M3.0-M5.7	M2.7-M4.4
SM48/O.E.	1700	247	40	8.0	9.5	0.55	0.5-4.5	5-45	<2.5	±3	M2.8-M5.8	M2.3-M4.7
SM50/O.E.	1400	247	40	8.0	9.5	0.55	0.7-5	7-50	<2.5	±3	M2.9-M6.0	M2.6-M4.9
SM55/O.E.	1000	247	40	8.0	9.5	0.55	0.7-6.5	7-65	<2.5	±3	M2.9-M6.4	M2.6-M5.4
SM60/O.E.	550	247	40	8.0	9.5	0.55	1.5-9.5	15-95	<2.5	±3	M4.1-M7.0	M3.3-M6.0
SM65/O.E.	300	247	40	8.0	9.5	0.55	3-18	30-180	<2.5	±3	M5.0-M9.3	M4.0-M7.2
SM68/O.E.	250	247	40	8.0	9.5	0.55	5-28	50-280	<2.5	±3	M6.0-M11.0	M4.9-M8.7

Air Nutrunner Push to Start Shut-off

(Immediate and Automatic air shut-off) -environment protect-



*Forward and Reverse for **SMP/O.E. type**

*Forward for **SMNP/O.E. type**

*For Model **SM(N)P10/O.E. ~ SM(N)P45/O.E.**

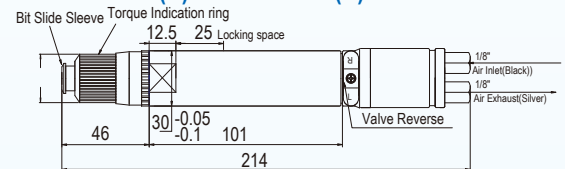

*For Model **SM(N)P48/O.E. ~ SM(N)P68/O.E.**

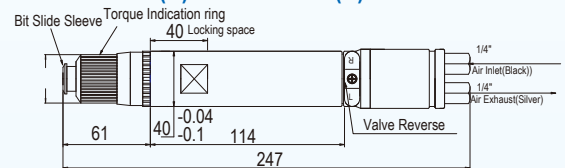

Model No.	Free Speed (r.p.m.)	O.A.L. (mm)	Dia. (mm)	Air hose bore		Air Consumption (m³/min)	Torque Range		Vibration Level (ms²)	Standard Deviation (%)	Fastening Capacity	
				6.0 Kg/cm³	5.0 Kg/cm³		N-m	Kgf-cm			Machine Screw	Tapping Screw
SM(N)P10/O.E.	1000	214	30	5.0	6.35	0.20	0.05-0.2	0.5-2	<1.0	±3	M1.0-M2.2	M1.1-M1.7
SM(N)P20/O.E.	1000	214	30	5.0	6.35	0.20	0.1-0.8	1-8	<1.0	±3	M1.7-M3.3	M1.3-M2.7
SM(N)P30/O.E.	1800	214	30	5.0	6.35	0.28	0.2-1.6	2-16	<1.2	±3	M2.2-M4.2	M1.6-M3.2
SM(N)P35/O.E.	2200	214	30	5.0	6.35	0.28	0.3-2	3-20	<1.2	±3	M2.4-M4.5	M2.0-M3.5
SM(N)P40/O.E.	1000	214	30	5.0	6.35	0.28	0.5-3	5-30	<1.2	±3	M2.8-M5.0	M2.3-M4.0
SM(N)P45/O.E.	800	214	30	6.35	8.0	0.30	0.8-4	8-40	<1.6	±3	M3.0-M5.7	M2.7-M4.4
SM(N)P48/O.E.	1700	247	40	8.0	9.5	0.55	0.5-4.5	5-45	<2.5	±3	M2.8-M5.8	M2.3-M4.7
SM(N)P50/O.E.	1400	247	40	8.0	9.5	0.55	0.7-5	7-50	<2.5	±3	M2.9-M6.0	M2.6-M4.9
SM(N)P55/O.E.	1000	247	40	8.0	9.5	0.55	0.7-6.5	7-65	<2.5	±3	M2.9-M6.4	M2.6-M5.4
SM(N)P60/O.E.	550	247	40	8.0	9.5	0.55	1.5-9.5	15-95	<2.5	±3	M4.1-M7.0	M3.3-M6.0
SM(N)P65/O.E.	300	247	40	8.0	9.5	0.55	3-18	30-180	<2.5	±3	M5.0-M9.3	M4.0-M7.2
SM(N)P68/O.E.	250	247	40	8.0	9.5	0.55	5-28	50-280	<2.5	±3	M6.0-M11.0	M4.9-M8.7

Air Nutrunner Air Start Shut-off

(Immediate and Automatic air shut-off) -Forward and Reversible type-
3 Air ways (2 for air in forward, reverse & 1 for air out)

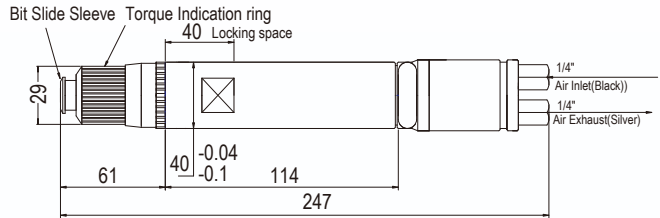

Model No.	Free Speed (r.p.m.)	O.A.L. (mm)	Dia. (mm)	Air Hose Bore		Air Consumption (m ³ /min)	Torque Range		Vibration Level (ms ²)	Standard Deviation (%)	Fastening Capacity	
				6.0 Kg/cm ³	5.0 Kg/cm ³		N-m	Kgf-cm			Machine Screw	Tapping Screw
SMR48/O.E.	180	247	40	8.0	9.5	0.55	0.5-4.5	5-45	<2.5	±3	M2.8-M5.8	M2.3-M4.7
SMR50/O.E.	1400	247	40	8.0	9.5	0.55	0.7-5	7-50	<2.5	±3	M2.9-M6.0	M2.6-M4.9
SMR55/O.E.	1000	247	40	8.0	9.5	0.55	0.7-6.5	7-65	<2.5	±3	M2.9-M6.4	M2.6-M5.4
SMR60/O.E.	550	247	40	8.0	9.5	0.55	1.5-9.5	15-95	<2.5	±3	M4.1-M7.0	M3.3-M6.0
SMR65/O.E.	300	247	40	8.0	9.5	0.55	3-18	30-180	<2.5	±3	M5.0-M9.3	M4.0-M7.2
SMR68/O.E.	250	247	40	8.0	9.5	0.55	5-28	50-280	<2.5	±3	M6.0-M11.0	M4.9-M8.7

Air Nutrunner Push to Start Shut-off

(Immediate and Automatic air shut-off) -Forward and Reversible type-
3 Air ways (2 for air in forward, reverse & 1 for air out)

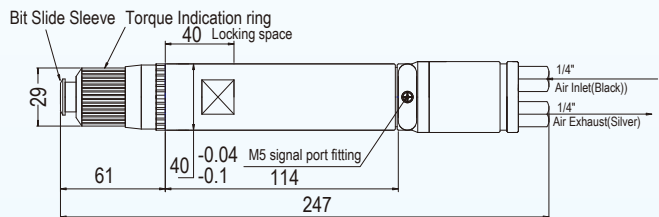

Model No.	Free Speed (r.p.m.)	O.A.L. (mm)	Dia. (mm)	Air Hose Bore		Air Consumption (m ³ /min)	Torque Range		Vibration Level (ms ²)	Standard Deviation (%)	Fastening Capacity	
				6.0 Kg/cm ³	5.0 Kg/cm ³		N-m	Kgf-cm			Machine Screw	Tapping Screw
SMR48/O.E.	1800	247	40	8.0	9.5	0.55	0.5-4.5	5-45	<2.5	±3	M2.8-M5.8	M2.3-M4.7
SMR50/O.E.	1400	247	40	8.0	9.5	0.55	0.7-5	7-50	<2.5	±3	M2.9-M6.0	M2.6-M4.9
SMR55/O.E.	1000	247	40	8.0	9.5	0.55	0.7-6.5	7-65	<2.5	±3	M2.9-M6.4	M2.6-M5.4
SMR60/O.E.	550	247	40	8.0	9.5	0.55	1.5-9.5	15-95	<2.5	±3	M4.1-M7.0	M3.3-M6.0
SMR65/O.E.	300	247	40	8.0	9.5	0.55	3-18	30-180	<2.5	±3	M5.0-M9.3	M4.0-M7.2
SMR68/O.E.	250	247	40	8.0	9.5	0.55	5-28	50-280	<2.5	±3	M6.0-M11.0	M4.9-M8.7

High Torque Oil Free Air Angle Wrench

Auto Shut-off

Features

- 1 High Accuracy: CMK Value $>1.33 \pm 10\%$ (According to ISO5393).
- 2 Extended tool body for comfortable operation and less reaction force.
- 3 Overall torque within Repeatability $\pm 3\%$.
- 4 Patented Right Angle Head
Innovational & robust right angle head for better performance.
- 5 Patented Clutch For Ergonomics
Reducing the extreme reaction force to the wrist.
- 6 Wider torque range selection
Torque adjustment range 6-120 Nm.
- 7 Reversible, delivers full torque in reverse
- 8 Times-Saving
Easy torque-adjusting operation.
- 9 Patented Motor
Output power is 30% more than other brands.

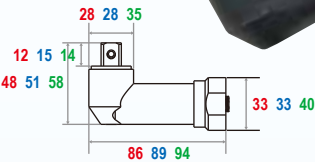

Standard Body

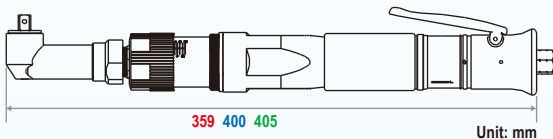

HAWF5180 ~ 5280 HAWF5400 ~ 5600 HAWF5700 ~ 51200

Extended Body

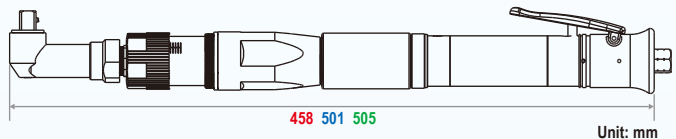

HAWFE5180 ~ 5280 HAWFE5400 ~ 5600 HAWFE5700 ~ 51200

Specification:

Model No.	Square Drive (inch)	Free Speed (r.p.m.)	Torque Range $\pm 3\%$		Overall Length		Noise Level $\pm 3\text{dB(A)}$	Air Pressure (kg-cm ²)	Min. air hose ID (mm)	Air Consumption (cfm)	Net Weight	
			N-m	kgf-cm	in	mm					lbs	kgs
HAWF5180	3/8	700	6-18	60-180	14.1	359	78	6	8	19	3.53	1.6
HAWF5250	3/8	430	10-25	100-250	14.1	359	78	6	8	19	3.53	1.6
HAWF5280	3/8	350	12-28	120-280	14.1	359	78	6	8	19	3.75	1.7
HAWF5400	1/2	250	10-40	100-400	15.75	400	82	6	8	23	5.07	2.3
HAWF5600	1/2	180	35-60	350-600	15.75	400	82	6	10	23	5.07	2.3
HAWF5700	1/2	130	35-70	350-700	15.94	405	82	6	10	23	5.73	2.6
HAWF51200	1/2	100	40-120	400-1200	15.94	405	82	6	10	23	5.73	2.6
HAWFE5180	3/8	700	6-18	60-180	18.03	458	78	6	8	19	3.97	1.8
HAWFE5250	3/8	430	10-25	100-250	18.03	458	78	6	8	19	3.97	1.8
HAWFE5280	3/8	350	12-28	120-280	18.03	458	78	6	8	19	3.97	1.8
HAWFE5400	1/2	250	10-40	100-400	19.72	501	82	6	8	23	5.29	2.4
HAWFE5600	1/2	180	35-60	350-600	19.72	501	82	6	10	23	5.29	2.4
HAWFE5700	1/2	130	35-70	350-700	19.88	505	82	6	10	23	7.28	3.3
HAWFE51200	1/2	100	40-120	400-1200	19.88	505	82	6	10	23	7.28	3.3

Composite Oil Free Air Reversible Die Grinder

Features:

- High quality Oil-free motor.
- Bi-way chuck with excellent concentricity and low vibration.
- All new patented mechanical design and comfort grip material.
- Patented horizontal forward switch and lock button design (For CG25S series).

- Friendly operation.
- Low vibration and longer usage term.
- Low noise.

Excellent Concentricity & Low vibration

The concentricity of chuck is within 0.05mm which extend grindstone usage term and makes the grinding surface lighter and smoother. Furthermore, SUMAKE excellent concentricity makes vibration much lower than other brand.



CG25 1/4" **CG25M** 6mm
CG25-1 1/8" **CG25M-3** 3mm
CG25M-8 8mm
Pistol Composite Air Die Grinder

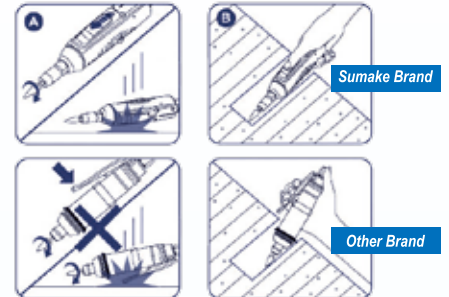

SUMAKE Patented Forward Switch design avoid incautious lever pressing due to drop on table or on floor, makes user more safe and convenient.
 SUMAKE Patented Forward Switch design eliminate troublesome to press throttle lever and reduce the operating space.

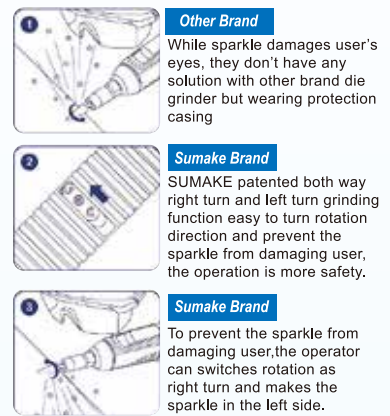
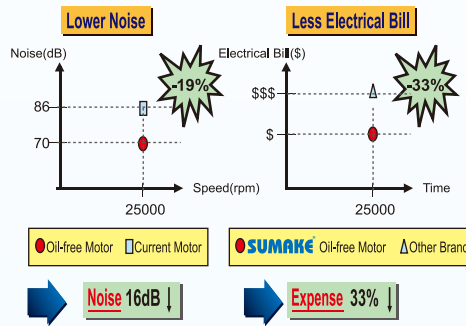
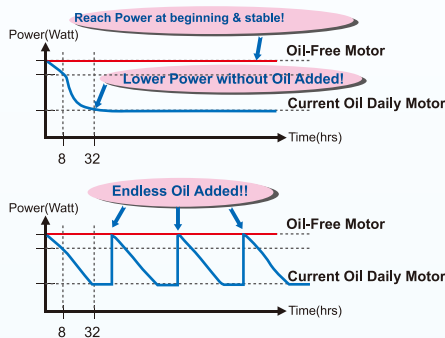

CG25S 1/4" **CG25SM** 6mm
CG25S-1 1/8" **CG25SM-3** 3mm
CG25SM-8 8mm
Straight Composite Air Die Grinder w/Lock Button



CG25SN 1/4" **CG25SNM** 6mm
CG25SN-1 1/8" **CG25SNM-3** 3mm
CG25SNM-8 8mm
Straight Composite Air Die Grinder

Model No.	Collect	Free Speed (r.p.m.)	O.A.L. (mm)	Dia (mm)	Weight		Air Consumption		Air Pressure		Min. Air Hose Bore		Noise Level dB(A)
					lbs	kg	cfm	m ³ /min	psi	kg/cm ²	inch	mm	
CG25	1/4"	25,000	180	39	1.52	0.69	10	0.28	90	6	1/5	5.0	70
CG25-1	1/8"	25,000	180	39	1.52	0.69	10	0.28	90	6	1/5	5.0	70
CG25M	6mm	25,000	180	39	1.52	0.69	10	0.28	90	6	1/5	5.0	70
CG25M-3	3mm	25,000	180	39	1.52	0.69	10	0.28	90	6	1/5	5.0	70
CG25M-8	8mm	25,000	180	39	1.52	0.69	10	0.28	90	6	1/5	5.0	70
CG25S(N)	1/4"	25,000	170	36	1.21	0.55	10	0.28	90	6	1/5	5.0	70
CG25S(N)-1	1/8"	25,000	170	36	1.21	0.55	10	0.28	90	6	1/5	5.0	70
CG25S(N)M	6mm	25,000	170	36	1.21	0.55	10	0.28	90	6	1/5	5.0	70
CG25S(N)M-3	3mm	25,000	170	36	1.21	0.55	10	0.28	90	6	1/5	5.0	70
CG25S(N)M-8	8mm	25,000	170	36	1.21	0.55	10	0.28	90	6	1/5	5.0	70

Telescopic Torque Arm & Auxiliary Arm

Features

- Eliminates torque reaction and removes weight of assembly tool from operator's arm and back.
- Easy to install on the workbench, wall, trolley or production line.
- Can be used with both air or electric torque tools.
- Best if used with a spring balancer (page 21).
- The arm collapses like a telescope providing smooth tool placement.
- Attachment clamp is free to move 360 degrees (see below pictures below).
- Standard tool balancer should be used to hang the tool while using this arm.
- Max torque capacity 50 Nm.
- Max reach is 120 cm; minimum reach is 43 cm.

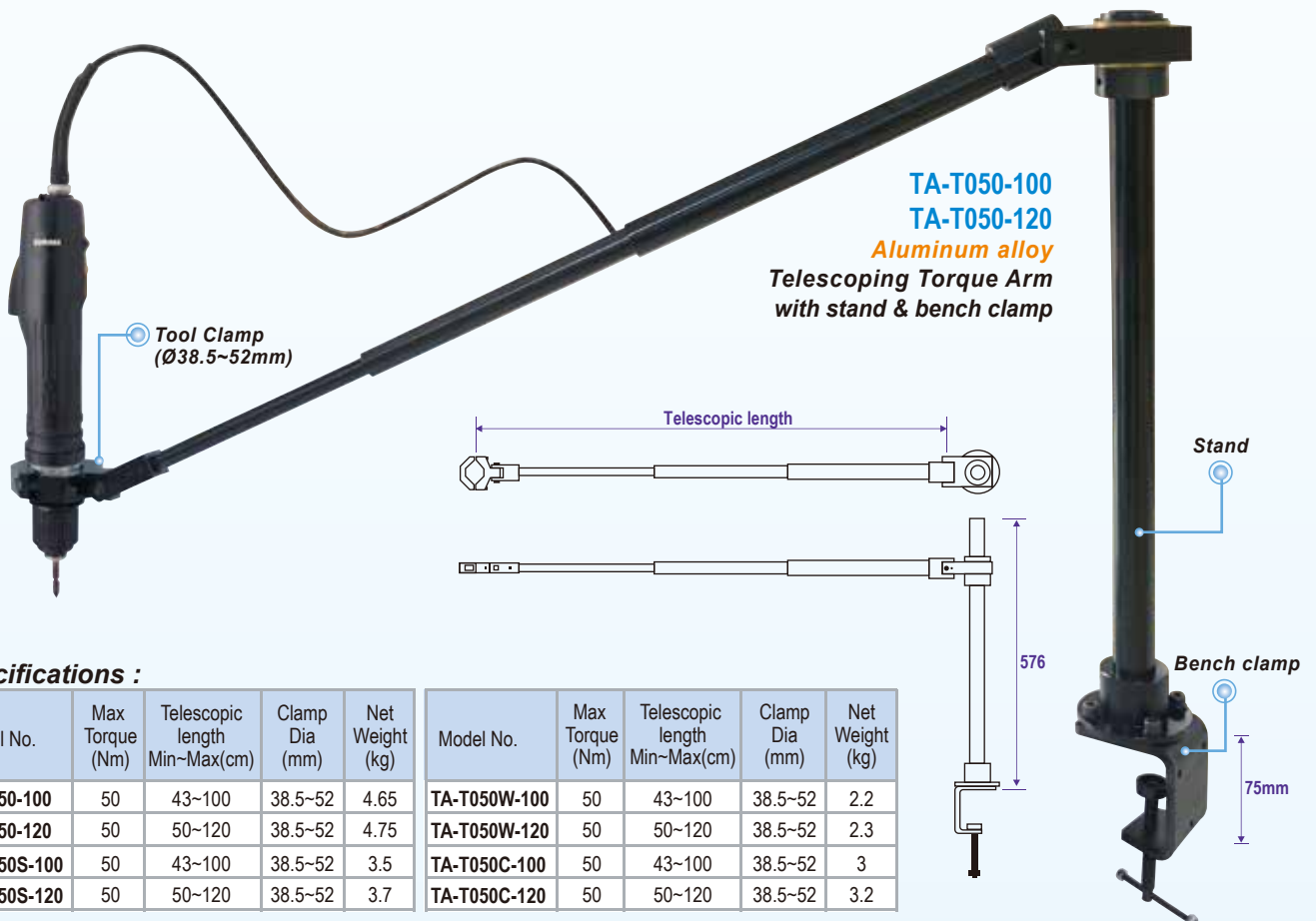

Specifications :

Model No.	Max Torque (Nm)	Telescopic length Min~Max(cm)	Clamp Dia (mm)	Net Weight (kg)	Model No.	Max Torque (Nm)	Telescopic length Min~Max(cm)	Clamp Dia (mm)	Net Weight (kg)
TA-T050-100	50	43~100	38.5~52	4.65	TA-T050W-100	50	43~100	38.5~52	2.2
TA-T050-120	50	50~120	38.5~52	4.75	TA-T050W-120	50	50~120	38.5~52	2.3
TA-T050S-100	50	43~100	38.5~52	3.5	TA-T050C-100	50	43~100	38.5~52	3
TA-T050S-120	50	50~120	38.5~52	3.7	TA-T050C-120	50	50~120	38.5~52	3.2

Tools Holster

Features:

- Suit for Various Air Tools (Straight/ Pistol Type), big and small size.
- Easy to keep the tool in the ready using position.
- Easy to adjust the holding angle.
- Keep the tools cleaning.
- Protect the tools from scratch.
- Net weight: 255g

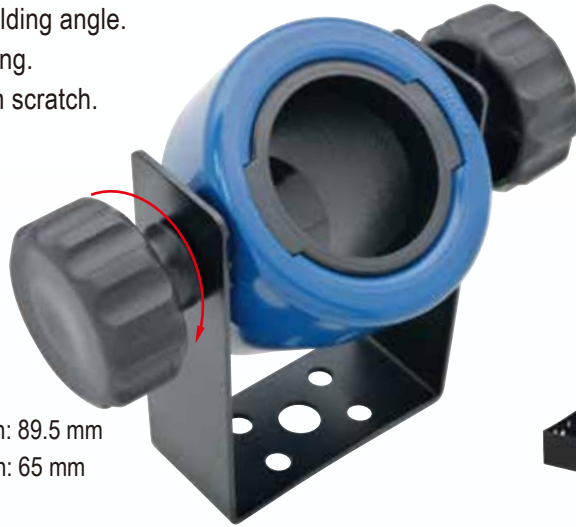

PH-0001 Side Length: 89.5 mm
PH-0001A Side Length: 65 mm
Tools Holster

Sample View



Surface View

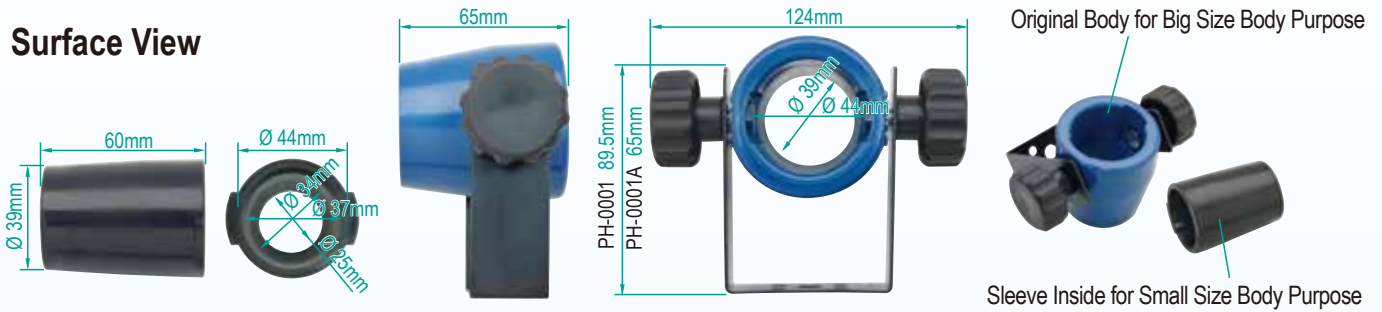

Spring Balancer



SB-1.2 (0.5-1.2kgs)
SB-2.0 (1.0-2.0kgs)
SB-3.0 (2.0-3.0kgs)
SB-4.0 (3.0-4.5kgs)
Spring Balancer



SA-2201 (0.3-0.8kgs)
SA-2203 (0.6-1.5kgs)
SA-2203-1 (1.0-2.0kgs)
SA-2204 (1.5-3.0kgs)
SA-2207 (3.0-5.0kgs)
Spring Balancer



SA-2204A (0.8-2.0kgs)
SA-2204B (0.3-1.2kgs)
Spring Balancer

Model No.	Capacity (kg)	Cable Travel (M)	Packing: Pcs/Ctn/G.W./Cuff' (kgs)
SB-1.2	0.5~1.2	1.6	20Pcs/Ctn/12.8/0.95'
SB-2.0	1.0~2.0	1.6	20Pcs/Ctn/12.8/0.95'
SB-3.0	2.0~3.0	1.6	20Pcs/Ctn/13.0/0.95'
SB-4.0	3.0~4.5	1.6	12Pcs/Ctn/10.3/1.1'

Model No.	Capacity (kg)	Cable Travel (M)	Packing: Pcs/Ctn/G.W./Cuff' (kgs)
SA-2201	0.3~0.8	1.4	40Pcs/Ctn/19.8/1.70'
SA-2203	0.6~1.5	1.4	40Pcs/Ctn/21.0/1.70'
SA-2203-1	1.0~2.0	1.4	40Pcs/Ctn/21.0/1.70'
SA-2204	1.5~3.0	1.4	40Pcs/Ctn/24.1/1.90'
SA-2204A	0.8~2.0	1.4	30Pcs/Ctn/19.5/1.60'
SA-2204B	0.3~1.2	1.4	30Pcs/Ctn/18.0/1.60'
SA-2207	3.0~5.0	1.3	30Pcs/Ctn/24/1.70'

SUMAKE[®] ISO 9001 CE

**AIR TOOLS
BEST BUY**

SUMAKE[®] ISO 9001 CE

**TRANSDUCERIZED
ELECTRIC TOOL**

SUMAKE[®] ISO 9001 CE

**ELECTRIC
SCREWDRIVER**

SUMAKE[®] ISO 9001 CE

**CORDLESS
TOOLS**

SUMAKE[®] ISO 9001 CE

**BRUSHLESS
ELECTRIC
SANDER**

SUMAKE[®] ISO 9001 CE

**AUTOMATIC
SCREW FEEDER
NIPPLE FEEDER**

SUMAKE[®] ISO 9001 CE

**SCREWDRIVER
BITS**

SUMAKE[®]

SUMAKE Industrial Co., Ltd.

4F, NO.351, Yangguang St., Neihu District, Taipei, Taiwan

Tel: 886-2-2659-3500

Fax: 886-2-2659-3700

<http://www.sumake.com>

<http://www.aircompressors.com.tw>

e-mail: sales@sumake.com.tw

2203



CATA-STSC22