

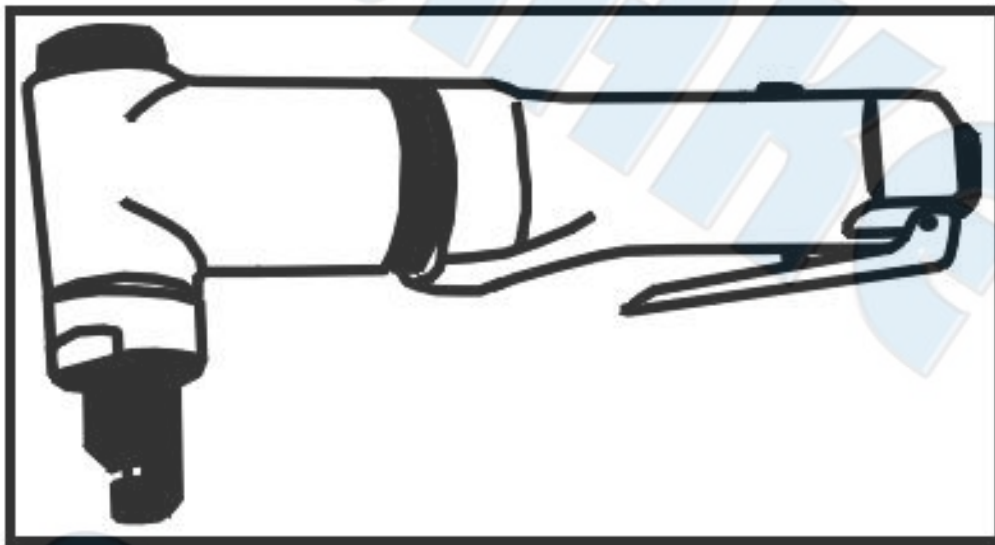

# SUMAKE PNEUMATIC TOOLS



## Air Nibbler (Pull Type) ST-6656

### Specification:

Blow Per Min	3,200 b.p.m.
Cutting Capacity (Gauge) Thickness	Steel 17G (1.4mm) Alum. 16G (1.6mm)
Air Consumption	10 CFM (283 L/min)
Air Inlet (PT)	1/4" (6.35 mm)
Air Hose (I.D.)	3/8" (10 mm)
Air Pressure	90 psi (6.3 bar)
Net Weight	2.64 lbs (1.2 kg)

### Noise and Vibration:

Vibration EN ISO 28927-7	Noise EN ISO 15744	Remark
No Load: 8.55 m/s <sup>2</sup>	Sound Pressure Level load: 85.5 dB(A)	Please always wear ear protector at environment noise level > 80 dB(A) due to risk of impaired hearing!
	Sound power level load: 96.5 dB(A)	
Uncertainty K= 1.35 m/s <sup>2</sup>	Uncertainty K= 3dB	

SUMAKE INDUSTRIAL CO., LTD

4F,NO.351,Yanguang St.,Neihu District TAIPEI, TAIWAN, ZIP:114-91

ST-6656-S-2111G-PZF



## EC DECLARATION OF CONFORMITY

We: **SUMAKE INDUSTRIAL CO., LTD.**

**4F, No. 351, Yangguang St., Neihu District, Taipei City, Taiwan**

declare in sole responsibility that the equipment

Equipment : **AIR NIBBLER (PULL TYPE)**

Model/ Serial No. : **ST-6656**

to which this declaration applies, complies with these normative documents:

- Machinery Directive: 2006/42/EC

and conforms to the following EN standard,

- EN ISO 12100: 2010
- EN ISO 11148-11:2011

Name and Signature/Position

Mike Su – Managing Director

Date and Place

2012/6/29

Taipei, Taiwan

ST-6656-D-1312D-PZF

## Foreword

Sumake is a manufacturer and exporter of air tools since established. We have devote all our efforts in improving quality and tools' life. As well as the noise and vibration of tools. Bring all of you working efficiencies, profits, and enjoy using the tool is our principle.

## Features

This tool is designed to meet an extremely wide range of metal materials to be cut into any shape, straight side or curved side.

## Operator's instruction

### 1. Main Applications

A breakthrough in cutting speed and durability. This lightweight, fast cutting tool is ideally suited for body shop and sheet metal work. Leaves sheet metal smooth and free from burrs and distortion.

### 2. Cautions for Use

#### 2-1 Air pressure

Maximum performance is displayed at the proper sanding speed, obtainable at a gauge pressure of 6.2 bar. Range-wise, this is an air pressure from 5 to 7 bar (70 to 100 psi)

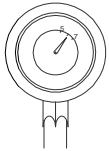

#### 2-2 Air line

Use a 3/8" air hose between the compressor and the tool. Compressed air is cooled and its water content separated, as soon as the air leaves the compressor.

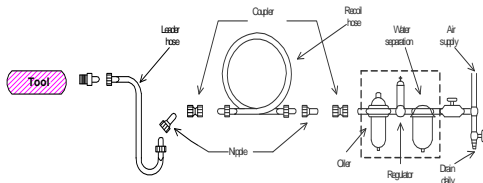

A portion of the water content, however, is condensed in the piping, and can enter the tool mechanism, and may cause trouble. So, install an air filter and on oiler between the compressor and the tool. Use a 3 HP or larger compressor for each sander.

#### 2-3 Air hose

Clean the hose with a blast of compressed air before connecting the hose to air tool. This will prevent both moisture and dust within the hose from entering the tool and causing possible rust or malfunction. To compensate for unusually long hose (over 25 ft), the line pressure should be increased accordingly.

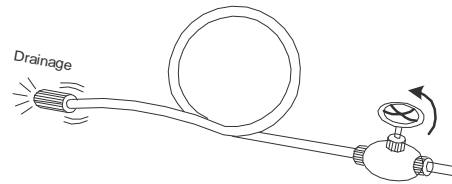

2-4 The approved eye protector, ear-muff, mouth-muffle, and gloves should be worn when operate this tool.

2-5 The working place shall be ventilative.

2-6 Release the on-off device in the case of energy supply failure.

### 3. Operation, Adjusting And Replacing Method

#### 3.1 On-off device

To operate this tool, just push the lever toward the tool itself. The tool continuously reciprocates as one push the lever down and it stops running as the lever is released.

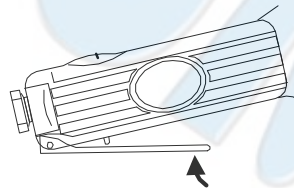

For the sake of safety, put it on hanger or on a soft flat pad when not in use.

### 3.2 Replace and adjusting

There is no user serviceable part inside this tool.

Please send the tool to a qualified personnel or our service section to repair or/and replace worn parts.

## 4. Maintenance

### 4-1 Lubrication

Before connecting the hose, apply 4 or 5 drops of #60 spindle oil at the air inlet. Use of a thicker oil can lead to reduced performance or malfunction. If a thicker oil is used by accident, wipe it away immediately. Also, every 3 or 4 hours of operation, oiling is necessary.

### 4-2 Storage

Avoid storing the tool in a location subject to high humidity. If the tool is left as it is used, the residual moisture inside the tool can cause rust. Before storing and after operation, oil the tool at the air inlet with spindle oil and run it for a short time.

### 4-3 Disposal

If the tool is too seriously damaged to be used anymore, drop it in a resource recycling can. Never drop it into fire.

### 4-4 Ordering service Parts

For further operational and handling information or for replacement of parts and components, contact the sale agent from whom you purchased the tool or the service division of our company.

\* In ordering parts and components, give each part number, name and quantity.

## Warning

1. This tool is not insulated for coming into contact with electric power source.
2. It is forbidden to use this tool in explosive atmospheres and do not put any combustible material near the workpiece since it emit sparks when grind with metal material.
3. The metal cutting trash might be sharp and it is blew out from the under part of Dies.
4. Prevent long hair or loose clothing from drawing in while operate this tool.
5. Never carry the tool by hose and beware of a whipping compressed air hose.
6. The workpiece shall be fixed by proper device.
7. Keep your body balance and beware of the fall of the severed workpiece.



ST-6656-I-1804B-PZ

# ST-6656 AIR NIBBLER

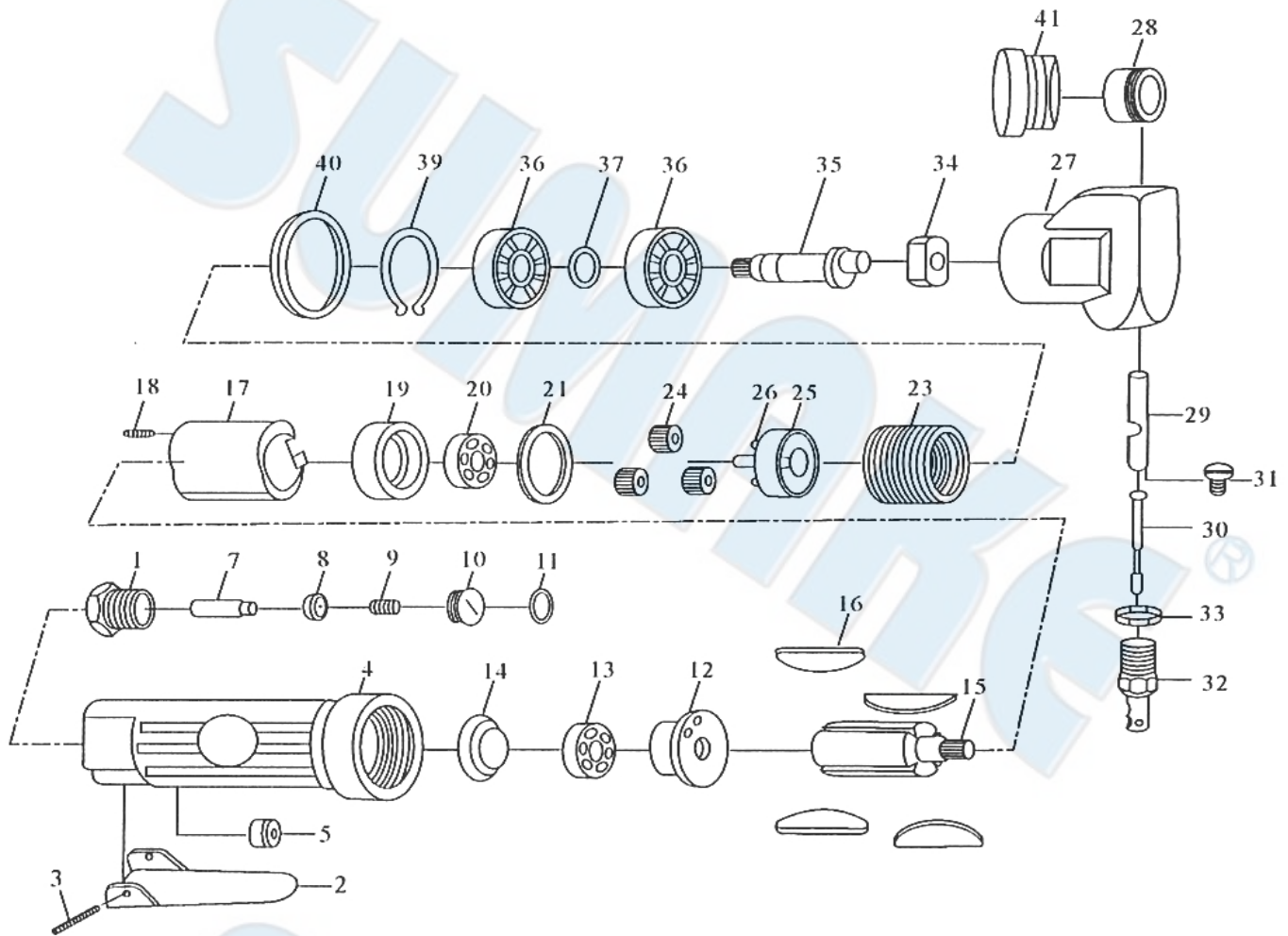

## PARTS LIST

No.	Parts No.	Description	Q'ty
1	6656-01	Air Inlet Bushing	1
2	6656-02	Throttle Lever	1
3	6656-03	Spring Pin [φ2.5x22]	1
4	6656-04	Handle Throttle	1
5	6656-05	Throttle Valve	1
7	6656-07	Valve Stem	1
8	6656-08	O-Ring [φ3x2]	1
9	6656-09	Spring	1
10	6656-10	Plug	1
11	6656-11	O-Ring [P8]	1
12	6656-12	Rear End Plate	1
13	6656-13	Bearing [626ZZ]	1
14	6656-14	End Plate Cap	1
15	6656-15	Rotor	1
16	6656-16	Rotor Blade	4
17	6656-17	Cylinder	1
18	6656-18	Spring Pin [φ2x6]	1
19	6656-19	Front End Plate	1
20	6656-20	Bearing [608ZZ]	1

No.	Parts No.	Description	Q'ty
21	6656-21	Washer	1
23	6656-23	Gear Case	1
24	6656-24	Idler-Gear	3
25	6656-25	Rear Spindle	1
26	6656-26	Idler Gear Pin [M4x14.8]	3
27	6656-27	Nibbler Head	1
28	6656-28	Pushing Rod Bushing	1
29	6656-29	Pushing Rod	1
30	6656-30	Cutter	1
31	6656-31	Screw	1
32	6656-32	Die	1
33	6656-33	Nut	1
34	6656-34	Drive Bushing	2
35	6656-35	Shaft	1
36	6656-36	Bearing [6200ZZ]	2
37	6656-37	Washer [φ10xφ22]	1
39	6656-39	Snap Ring [R30]	1
40	6656-40	Nut	1
41	6656-41	Plug	1